

Front View

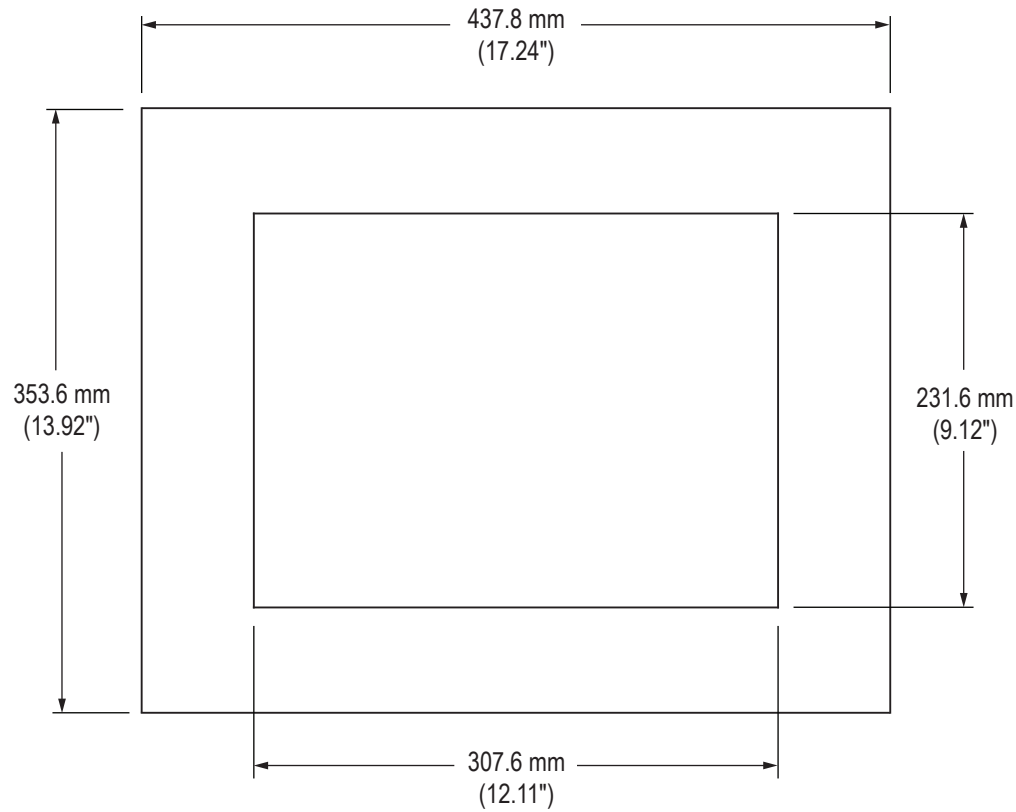

Side View

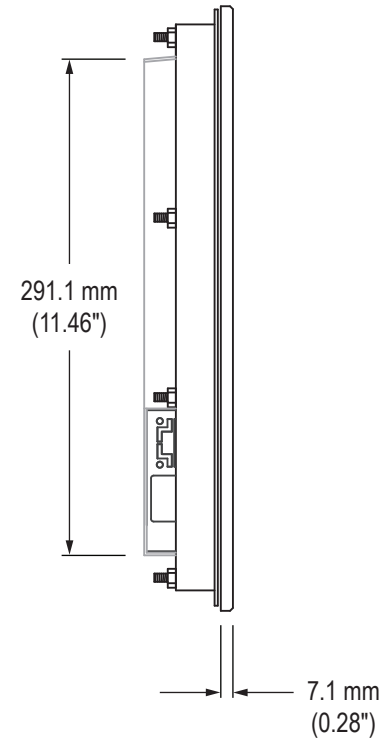

Rear View (showing Cutout Dimensions)

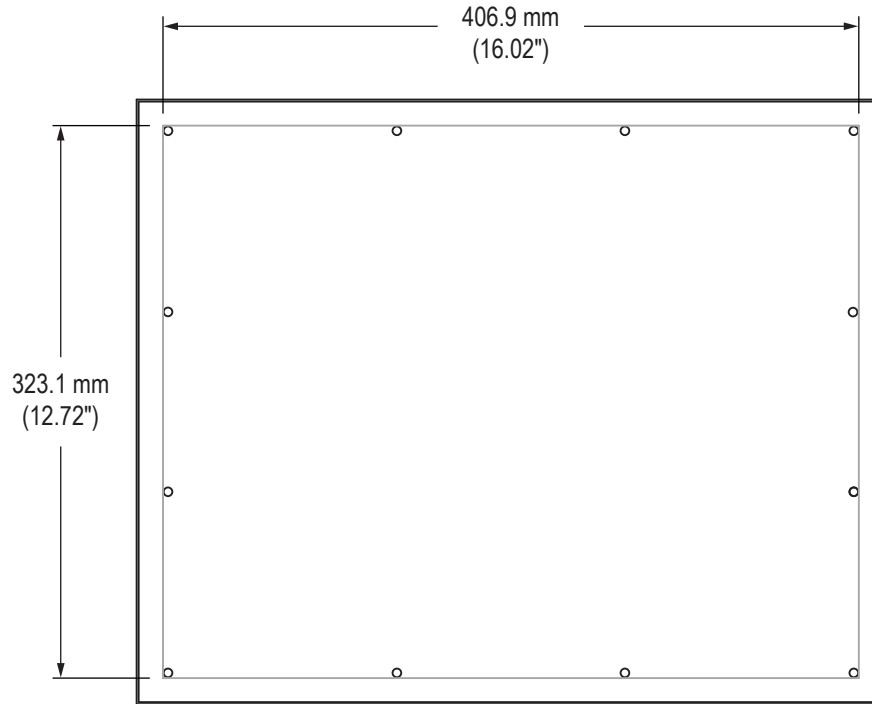

Bottom View

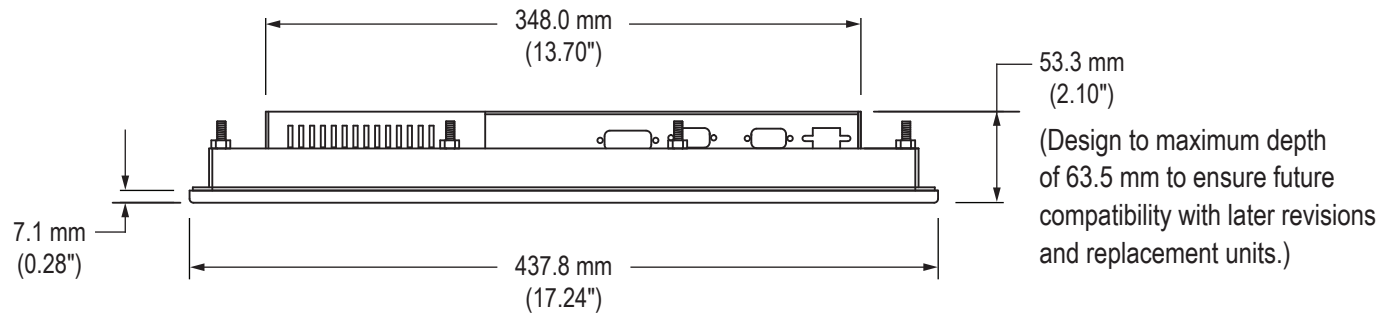

Cable Connections

Rear View

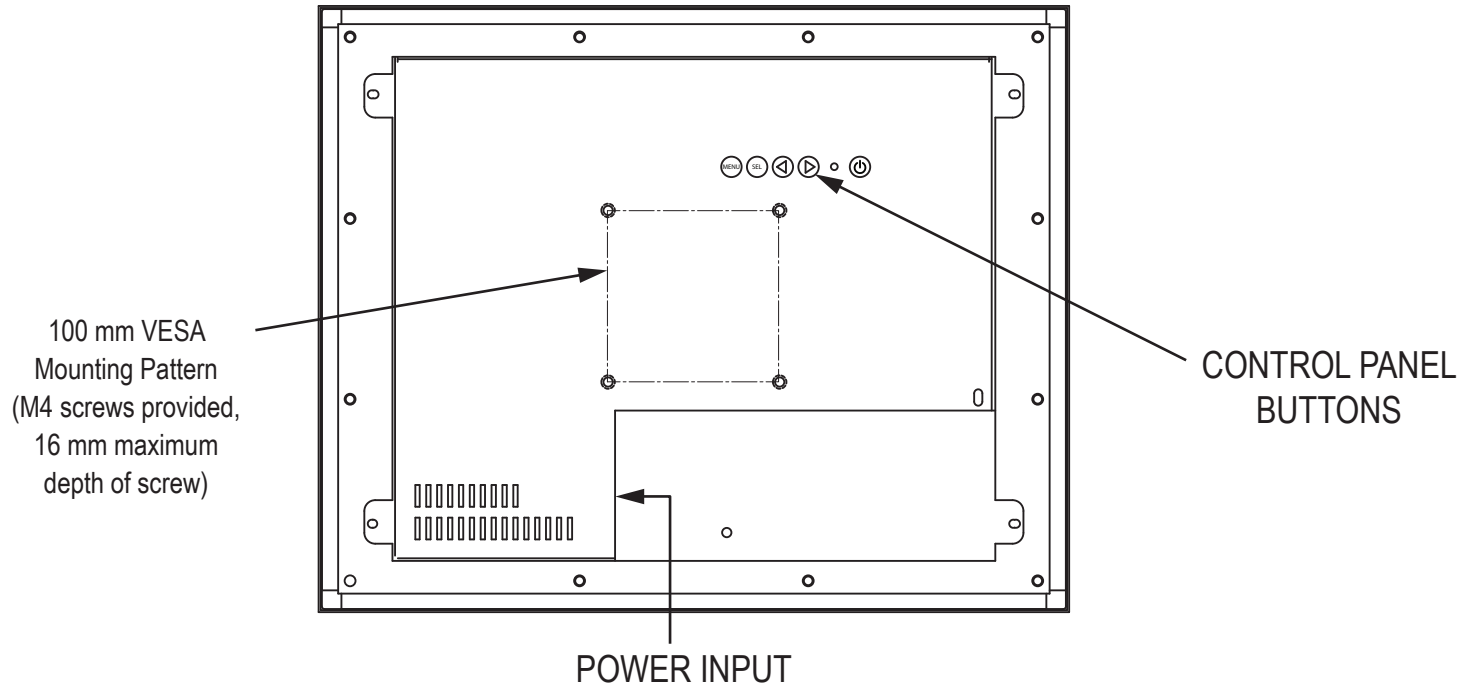

Bottom View

